

# Champion®

The Dishwashing Machine Specialists

PROJECT: \_\_\_\_\_

ITEM # \_\_\_\_\_ QTY: \_\_\_\_\_

MODEL # \_\_\_\_\_

AIA # \_\_\_\_\_ SIS # \_\_\_\_\_

## RW-66

### POT, PAN AND UTENSIL WASHER



Shown with optional fold-away ramp

Rendered image is for general visual representation only. Please refer to specifications for the latest detailed product information.

### STANDARD FEATURES

- **Heavy-Duty Stainless Steel Construction**
- **66 Sheet Pan Capacity**
- **Easy To Clean Dual Filtration System**
- **Adjustable Wash and Rinse Cycles**
- **Moisture Resistant Control Gauges**
- **Choice of Tank Heat:**  
Electric or Steam
- **Fresh Water Sanitizing Rinse**
- **Digital Control And Information Center**
- **25 HP Wash Pump**
- **Double Skinned, Hinged Door Design**
- **Self-Contained Water Heater**
- **Recirculating Wash Water**
- **Precision Engineered Spray Pattern**
- **One Year Parts and Labor Warranty**
- **High-Pressure Wash System (35-45 PSI)**

### OPTIONS

Additional Panwasher and Rackwasher Models:

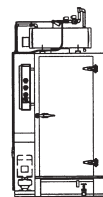

RW-36

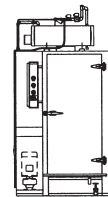

RW-54

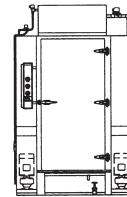

RW-72



#### In the USA:

3765 Champion Blvd, Winston-Salem, NC 27105  
Tel: (336) 661-1556 Fax: (336) 661-1979  
[www.championindustries.com](http://www.championindustries.com)

#### In Canada:

2674 N. Service Rd., Jordan Station, Ontario, Canada LORISO  
Tel: (905) 562-4195 Fax: (905) 562-4618  
[www.championmoyerdiebel.ca](http://www.championmoyerdiebel.ca)

#### SPECIFICATIONS

<b>Machine Construction</b>	12, 14, & 16 gauge stainless steel. All seams Tig welded.
<b>Door</b>	Double skinned stainless steel with exterior latch and inside release handle.
<b>Spray Arm Assembly</b>	Water driven, stainless steel, spray arm assembly with stainless steel jets, removable end caps and hand-operated, quick-release mechanism for easy cleaning and reassembly. Mounted on stainless steel base.
<b>Filter</b>	Perforated stainless steel screen type. Double filtration system for increased effectiveness and easy cleaning without emptying the tank.
<b>Water Pump</b>	25 H.P., 208/240/480 volt, 3 phase, 60 cycle with output of 430 gallons per minute at 40 to 50 P.S.I.
<b>Digital Control &amp; Information Center</b>	120 volt control circuit with push pad operation of "Power On", "Stop" and "Short, Medium or Long Wash Cycles". A digital display indicates "Time Remaining" for each cycle. LED's indicate wash, rinse and unload functions. A buzzer is also included to provide an audible indication of time to unload. A pre-programmed circuit board allows the push pad to be used as a "Diagnostic Center" by displaying "Error Codes" for ease of troubleshooting.
<b>Gauges</b>	Moisture resistant gauges measure wash temperature, wash pressure and rinse temperature.
<b>Wash Tank</b>	Stainless steel with electric, steam or steam coil heating, thermostatically controlled, low water protected, sloped to drain with a 180-gallon capacity.
<b>Rinse Tank</b>	Stainless steel with one electric, infrared or steam coil heating to provide 180°F/190°F hot sanitizing rinse.
<b>Racks</b>	Stainless steel built to match specific washing requirements.

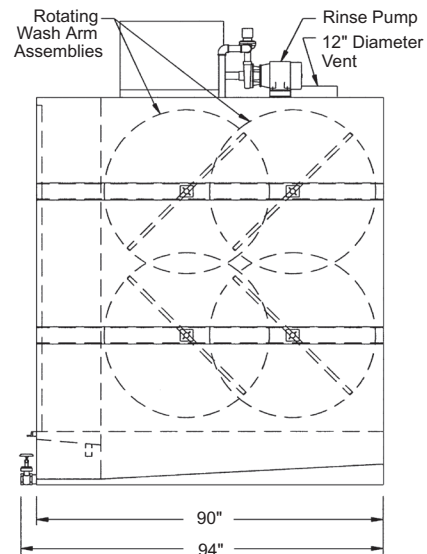
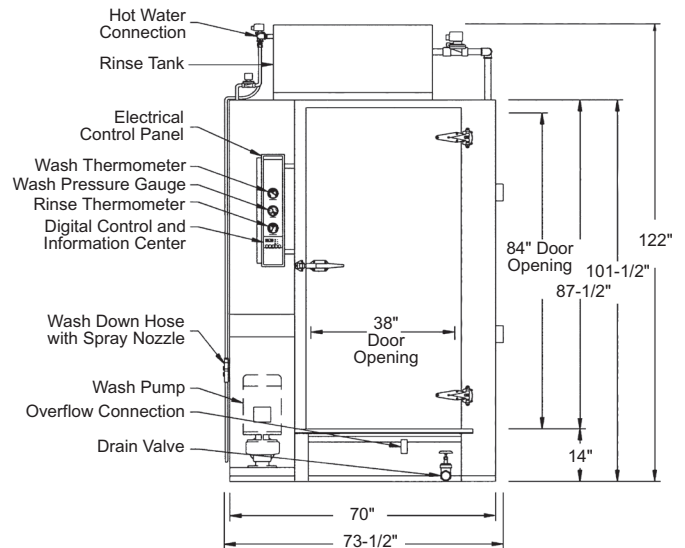

**Certifications** UL and UL Sanitation Listed (all). CUL Listed (electric and steam only).

**Note** Water Hammer Arrestor (meeting ASSE-1010 standard or equivalent) to be supplied (by others) in Common water supply line at service connection.

#### Warning

Plumbing and electrical connections should be made by qualified personnel who will observe all the applicable plumbing, sanitary, and safety codes and the National Electrical Code.

#### Plumbing Notes

Because of the variation in house-supplied steam and water pressures, steam and water pressure regulating valves (PRVs) may be needed. (Water PRV is standard on machines with booster.) The PRVs can either be purchased from Champion or obtained locally. Champion does not endorse using on-demand (tankless) water heating systems, as well as PEX and other plumbing materials that may limit water flow, as these could impair machine performance. For optimal results, we recommend using appropriately sized conventional hot water tanks and standard copper water supply lines that adhere to our specifications. Not following these recommendations may void the manufacturer's warranty. Water hardness of 3 grains/US Gal (0.83 Imp Gal) - 5.3 Mg/L or less

<b>Cabinet</b>	70" wide x 90" deep (100" for pass through option) x 101 1/2" high. Door Opening: 38" wide x 84" high. Wash Chamber: 37" wide x 72" deep x 83" high. Constructed of #14 gauge, #304 STAINLESS STEEL with a #3 finish. All seams are tig or mig welded. Seams, where needed for watertight construction, are continuously welded. All other seams are stitch welded for strength. All welds are cleaned inside, cleaned and buffed outside. Optional continuous welds in lieu of stitch welds available.
<b>Door</b>	Constructed of #16 and #18 gauge, #304 STAINLESS STEEL with a #3 finish. Door is double skinned with integral framework for additional strength. Standard right hand, or optional left hand swing, equipped with external latch, inside release handle and is interlocked to prevent machine operation while open.
<b>Washer Floor</b>	Constructed of #12 gauge, #304 STAINLESS STEEL formed sheets designed to provide maximum strength. Supports constructed of 1 1/2" STAINLESS STEEL piping.
<b>Recirculating Wash Tank</b>	Constructed of #14 gauge, #304 STAINLESS STEEL, heated by 42 KW electric immersion heaters, live steam or steam coil. Complete with low water protection, automatic fill, 1 1/4" NPT overflow connection, 2" gate drain valve, thermometer, pressure gauge and is thermostatically controlled. 180 gallon tank capacity, sloped to drain.
<b>Wash Tank Filter</b>	Perforated, stainless steel baskets. Designed for increased effectiveness and easy cleaning without emptying wash tank.
<b>Wash Tank Fill Valve</b>	Size 3/4" brass material, solenoid type for automatic.
<b>Wash Tank Drain Valve</b>	Size 2" brass material, gate type for manual or electrically operated ball valve for automatic option.
<b>Wash Pump</b>	Closed coupled centrifugal wash pump, bronze fitted with cast iron casing. Complete with 25 H.P. ODP motor (optional TEFC or wash down duty motors available). 208/240/480 or optional 575 volt, 3 phase, 60 cycle. Rated for 430 gallons per minute at 35 to 45 PSI. Optional STAINLESS STEEL wet end available.
<b>Rotating Wash Hub &amp; Spray Arm Assembly</b>	Water driven, stainless steel spray arm assembly with stainless steel jets removable end caps and hand operated quick release mechanism for easy cleaning and reassembly. Mounted on stainless steel base.
<b>Filtration</b>	Perforated STAINLESS STEEL screen type. Double filter system for increased effectiveness and easy cleaning without emptying wash tank.
<b>Sanitizing Pumped Rinse Tank</b>	Constructed of #14 gauge, #304 STAINLESS STEEL, heated by 42 KW electric immersion heaters or steam coil. Complete with low water protection, automatic fill, and thermostatically controlled to provide 20 gallons per 30 second cycle at 20 PSI and has a 60 gallon capacity. Also supplied with a closed coupled centrifugal pump with STAINLESS STEEL casing and impeller. 1 1/2 H.P. TEFC or optional wash down duty motor. 208/240/480 or optional 575 volt, 3 phase, 60 cycle.
<b>Final Rinse Piping</b>	#304 STAINLESS STEEL tubing with brass compression fittings and full cone rinse jets. Optional STAINLESS STEEL fittings and jets are available.
<b>External Rinse Hose</b>	Externally mounted rinse hose with spray gun for easy cleaning and maintenance of machine.
<b>Steam Exhaust Vent</b>	Steam exhaust vent 12 7/8" I.D. consisting of #16 gauge rolled collar for PVC pipe connection bolted to the top of the machine. Machine pre-wired with control timer for the addition of a fan.
<b>Optional Exhaust Fan</b>	One (1) 12" diameter fan with 12 7/8" I.D. collar mounted on washer to extract excess steam after final rinse cycle. Constructed of STAINLESS STEEL housing and aluminum blade with 1/3 H.P. TEFC or optional wash down duty motor, 208/240/480 or optional 575 volt, 3 phase, 60 cycle. 1725 RPM, rated 500 CFM at .5" static pressure. Optional fan with STAINLESS STEEL housing and blade with 3/4 H.P. motor is available.

#### Electrical Enclosure & Controls

Electrical enclosure is UL 12 STAINLESS STEEL with Sq. "D" components. Optional disconnect switch with safety lockout is available. Includes 120 volt control circuit and motor starters. Digital Control and Information Center consists of push pad operation of "POWER ON", "SHORT, MEDIUM or LONG" wash cycles. Also included is a digital display which indicates time remaining, cycle indicator lights and a buzzer to indicate full cycle completion. The display along with the push pad can also be used as a diagnostic center by displaying error codes for ease of troubleshooting. Moisture resistant gauges measure temperatures and pressures for wash and rinse cycles. Optional UL 4X STAINLESS STEEL electrical enclosure with three way selector switch, push button controls and adjustable timers or Schneider Modicon PLC with Magellis 5.7 color operator interface touch screen including ethernet and data logging capabilities in lieu of Digital Control and Information Center. Washer will be wired in hard aluminum conduit and tested prior to shipment.

#### Optional Hood & Exhaust Fan Assembly

STAINLESS STEEL hood with 15" diameter fan mounted over door and activates upon door opening to evacuate steam that escapes. Constructed of STAINLESS STEEL housing and blade with 1 1/2 H.P. TEFC or optional wash down duty motor, 208/240/480 or optional 575 volt, 3 phase, 60 cycle, 3450 RPM, rated for 2450 CFM at .56" static pressure.

#### Racks

Customized to hold your specific items. Constructed of STAINLESS STEEL rod, square tubing and formed angle, mig welded. Supplied with STAINLESS STEEL casters and nylon wheels, fixed front and swiveled rear.

#### Connections

Water Inlet: 1" NPT, 120° F.  
 Drain: 2" NPT  
 Overflow: 1 1/4" NPT  
 Steam Option: (2) 3/4" NPT  
 Steam Condensate: (2) 3/4" NPT  
 Electrical: Single-point connection.

#### Utilities

See attached Utilities Chart for service requirements specific to various combinations of wash and rinse tank heating. Calculations are based on a room temperature of 72° F.

#### Electrical Connections

Contact factory for mixed heat sources.

RW-66	Running Amps	
Elec. Specs	Electric Wash Electric Booster	Amp Minimum Service Break
208/60/3	303	400
240/60/3	262	350
480/60/3	132	175
575/60/3	108	150

RW-66	Running Amps	
Elec. Specs	Steam Wash Steam Booster	Amp Minimum Service Break
208/60/3	70	90
240/60/3	60	80
480/60/3	31	40
575/60/3	24	30

Steam Consumption: 350 lbs. per hour at 15 PSI minimum.

#### Additional Amps

Please add the following running amps to those noted above for an optional exhaust fan (1.9 at 208 volt, 1.6 at 240 volt, .6 at 480 volt and .33 at 575 volt) and/or optional hood and fan assembly (5.6 at 208 volt, 5.4 at 240 volt, 2.7 at 480 volt, and 2 at 575 volt) and recalculate service breaker size, which should be at least 125% of total running amps.