

Champion®

The Dishwashing Machine Specialists

PROJECT: _____

ITEM # _____ QTY: _____

MODEL # _____

AIA # _____ SIS # _____

PP-28

DOOR TYPE POT, PAN, AND UTENSIL WASHER



Rendered image is for general visual representation only. Please refer to specifications for the latest detailed product information.



STANDARD FEATURES

- Factory authorized startup
- Balanced door system
- Detergent/chemical connection provisions
- Door safety switch on each door
- Enclosure panels (front and sides)
- External lift-out refuse basket
- Fully automatic wash and rinse cycle
- Hold-down grid
- 7.5-Hp drip-proof pump motor
- Interchangeable upper and lower wash and rinse arms
- Recessed, front-mounted controls
- Six-inch diameter vent connection
- Electric wash tank heat
- Bake sheet rack
- Utility rack

OPTIONS & ACCESSORIES

- Corner Operation
- Straight-through Operation
- Front-loading Operation
- 10" Shelf on front-loading machine
- Steam Coil tank heat
- Steam Injector tank heat
- Boosters, Stainless Steel (completely interplumbed, controls are interwired)
- Steam: 40°F Rise (built-in) (externally mounted with cover for corner model)
- Steam: 70°F Rise (externally mounted with cover)
- Electric: 40°F Rise (built-in) (externally mounted with cover for corner model)
- Electric: 70°F Rise (externally mounted with cover)
- Exhaust Fan, 1/3 Hp
- Racks, Stainless Steel (5" x 28" x 28")

SPECIFIER STATEMENT

Specified unit will be Champion model PP-28 pot, pan, utensil door type washing machine. Features adjustable wash cycle depending on solid wares from 2 to 5 minutes, revolving upper and lower high pressure spray arms, large wash chamber spacious enough to accommodate 140 quart mixing bowls, fully automatic operation, and made entirely of heavy gauge stainless steel from the base to spray arms. One year parts and labor warranty. **1 year parts and labor warranty.**

In the USA:
3765 Champion Blvd, Winston-Salem, NC 27105
Tel: (336) 661-1556 Fax: (336) 661-1979
www.championindustries.com

In Canada:
2674 N. Service Rd., Jordan Station, Ontario, Canada LORISO
Tel: (905) 562-4195 Fax: (905) 562-4618
www.championmoyerdiebel.ca

Champion®

The Dishwashing Machine Specialists

PP-28

DOOR TYPE POT, PAN, AND UTENSIL WASHER

Shipping weight crated: 1100 lbs. Shipping weight crated with built-in booster: 1200 lbs. Dimensions shown in inches

SPECIFICATIONS

Capacities

Racks per hr. (NSF rated)	25
Wash tank (gal.)	24

Motor Horsepower

7.5 HP

Pump Capacity (gpm)

280

Wash Nozzle Pressure (ft of head)

50

Water Consumption

Gal. per hr. (max use)	82
Gal. per rack	3.3

Temperature °F

Wash	150
Rinse	180

Heating

Tank heat, electric	10 kW
Tank heat, steam	
(lb/hr at 15 psi flow pressure)	50 lb/hr
Electric booster (kW required for 40°F rise)	27 kW
Electric booster (kW required for 70°F rise)	45 kW
Steam booster consumption (lb/hr for 40° rise)	50 lb/hr
(Instantaneous demand lb/hr 40° rise)	350 lb/hr
Steam booster consumption (lb/hr for 70°F rise)	85 lb/hr
(Instantaneous demand lb/hr 70° rise)	615 lb/hr

Time Cycle

Wash – adjustable (minutes)	2-5
Rinse (seconds)	16

Typical Table Construction

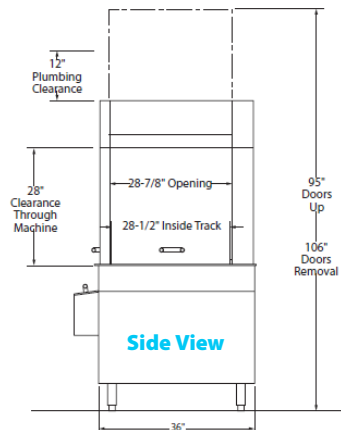
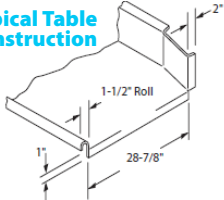

Machine Load Amps				
Elec. Specs	Electric Heat	Steam Heat	Electric Heat & Exhaust Fan	Steam Heat & Exhaust Fan
208/60/3	50	22	53	25
240/60/3	45	21	48	24
480/60/3	22	11	24	13

Warning: Plumbing and electrical connections should be made by qualified personnel who will observe all the applicable plumbing, sanitary and safety codes and the National Electrical Code.

Note: Water Hammer Arrestor (meeting ASSE-1010 standard or equivalent) to be supplied (by others) in common water supply line at service connection. Recommended water hardness to be 3 grains or less for optimal performance results.

Optional Drain Tempering: 1/2" NPT cold water connection required. 1/2" NPT drain connection from back flow preventer to house drain. (FIELD INSTALLED and PLUMBED).

Plumbing Notes: Because of the variation in house-supplied steam and water pressures, steam and water pressure regulating valves (PRVs) may be needed. (Water PRV is standard on machines with booster.) The PRVs can either be purchased from Champion or obtained locally.

Champion does not endorse using on-demand (tankless) water heating systems, as well as PEX and other plumbing materials that may limit water flow, as these could impair machine performance. For optimal results, we recommend using appropriately sized conventional hot water tanks and standard copper water supply lines that adhere to our specifications. Not following these recommendations may void the manufacturer's warranty.

Water hardness of 3 grains/US Gal (0.83 Imp Gal) – 5.3 Mg/L or less

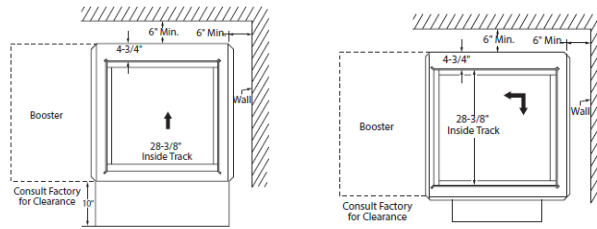

Front Loading Operation

Corner Operation

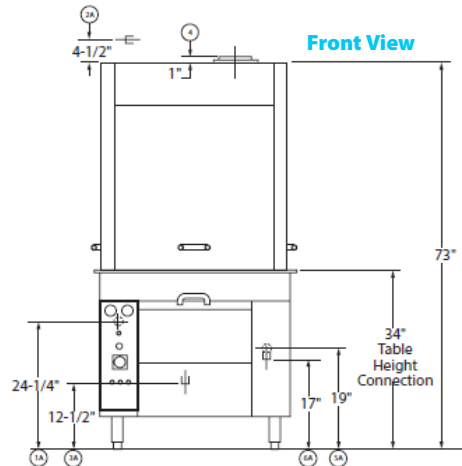

Front View

Note: For 70°F rise booster connections and load amps, contact factory. For corner model booster connections and load amps, contact factory. For booster connections contact factory.

Load Amps Electric Booster (40° Rise) (27 kW) (When specified)

Voltage	PP-28
208/60/3	75
240/60/3	65
480/60/3	34

Utilities

- Electrical**
 - A** See box (1) for machine connection.
 - B** See box (2) for separate built-in 27 kW electric booster connection.
- Hot Water**
 - A** 1" NPT 180°F connection. Flow pressure 20-22 psi/825 gph @ rate of usage 135 gpm
 - B** 1" NPT 140°F connection. Flow pressure 20-22 psi/825 gph. Unmounted water PRV provided.
- Drain**
 - A** 1-1/2" NPT connection. Maximum flow 15 gpm.
 - B** 3/4" NPT steam booster relief to open drain.
- Vent**
 - 6" diameter. 200 CFM. (Contact the factory for optional exhaust fan connections).
- Steam**
 - A** 3/4" NPT connection. Flow pressure 15-30 psi. (Tank heat only).
 - B** 1-1/4" NPT connection (Tank & Booster 40° rise).
 - 2" NPT connection (Tank & Booster 70° rise). Consult factory for location
- Condensate**
 - A** 1/2" NPT machine connection return to boiler (steam coil heat only).
 - B** 3/4" NPT machine connection return to boiler (steam heat, steam booster).

In the USA: 3765 Champion Blvd, Winston-Salem, NC 27105 | Tel: (336) 661-1556 Fax: (336) 661-1979 | www.championindustries.com

In Canada: 2674 N. Service Rd., Jordan Station, Ontario, Canada LORISO | Tel: (905) 562-4195 Fax: (905) 562-4618 | www.championmoyerdiebel.ca

Rev. 1/2026 Printed in U.S.A.

Due to an ongoing value analysis program at Champion, specifications contained in this catalog are subject to change without notice.

Steam Booster (40° Rise)

Plan View

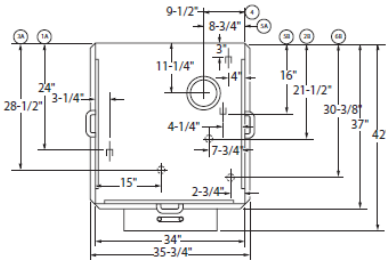

Electric Booster (40° Rise)

Plan View

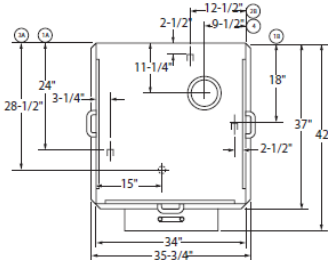

Front View

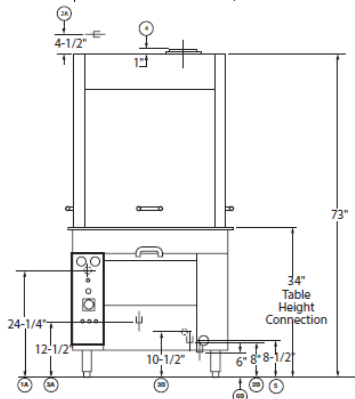

Front View

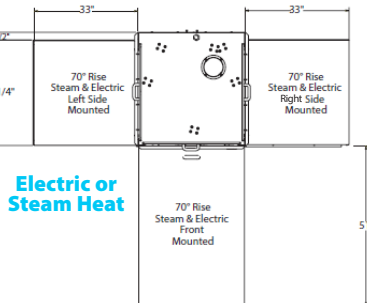
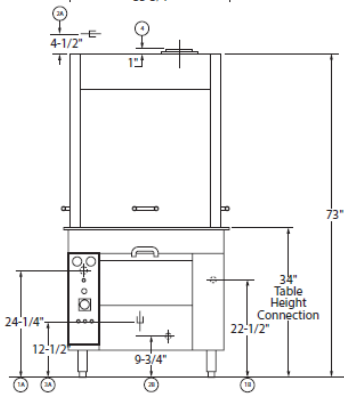

Electric or Steam Heat

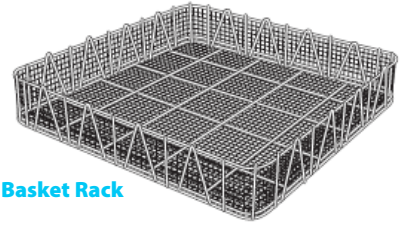

Basket Rack

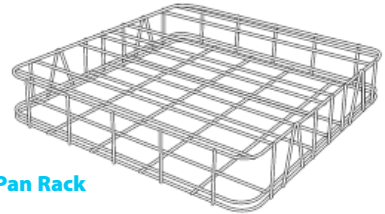

Pan Rack

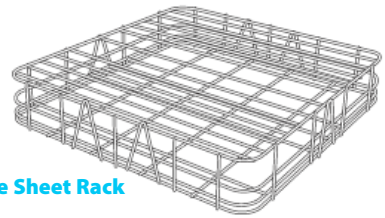

Bake Sheet Rack

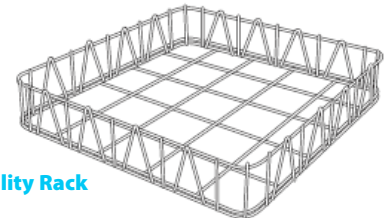

Utility Rack

ACCESSORIES

- Basket Rack (utensils and loose items) P/N 109584
- Pan Rack (baking pans) P/N 109585
- Bake Sheet Rack (baking sheet) P/N 109587
- Utility Rack (large pots and pans) P/N 109586